



## Consolite® Technology Ltd

St. Martins Business Park, Bells Lane, Zeals, Wiltshire, BA12 6LY, UK

Tel: +44 (0) 1747 840900 - E mail: sales@consolite.co.uk

Certified to ISO9001:2015

### CTL-426-001 Bunk Light, LED, Interior

A low profile LED bunk light fixture with adjustable white light.  
Robust steel design, with dimming controls and two USB charging ports.

#### Features:

- LED technology - low power, high reliability
- Warm white light, dimmable
- Rugged construction, folded and stainless steel body
- Low profile front panel
- 2 USB-A ports for connecting and charging devices
- Electronic control to prevent run away charging
- Designed to replace 6230-99-500-4508



CTL-426-001



## Consolite® Technology Ltd

St. Martins Business Park, Bells Lane, Zeals, Wiltshire, BA12 6LY, UK

Tel: +44 (0) 1747 840900 - E mail: sales@consolite.co.uk

Certified to ISO9001:2015

### Installation Data

<b>Dimensions (mm)</b>	200 x 130 x 33.5 (recessed installation, front panel protrudes 1.5mm)
<b>Input Voltage (V)</b>	115 A/C
<b>Weight (kg)</b>	0.75
<b>Light Output</b>	Warm white colour (3000K), 100lm
<b>Material</b>	Stainless Steel Finished with Traffic White (RAL 9016) graphic
<b>IP rating</b>	IP44 when fitted to the bulkhead and USB bungs fitted

### Dimensional drawing

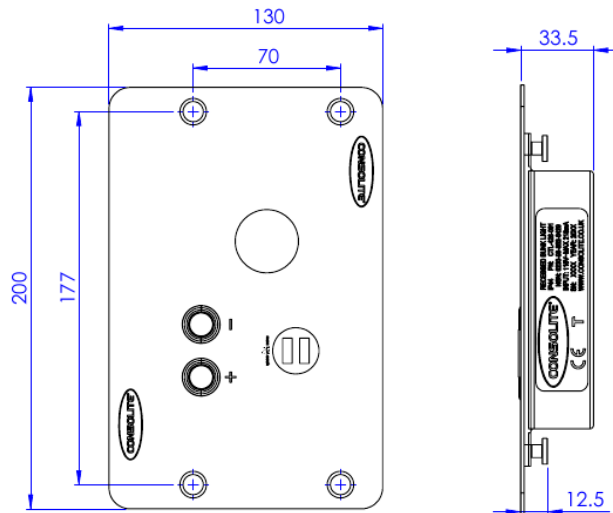

### Standards

EMC compliant IAW Def Stan 59-411, IEC 60945

Electrical safety tested IAW BS EN 60598-1

Consolite is a long established leader in night vision lighting for military platforms, designing and manufacturing lighting for NVGs for over 25 years, including lighting for aircraft, ships and ground use.

Consolite's design facility permits the calculation of lighting requirements for any space from a single compartment to an entire ship.

Consolite's test facility includes the latest equipment required for testing night vision compliance to any relevant standard plus goniophotometric equipment for full 360 degree light characterisation of luminaire output.