



Consolite Technology Data Sheet

NVG Compatible LED Panel Indicators

A range of NVIS compatible panel mounting indicator light assemblies for aircraft, vehicle and boat control panels. The light sources are LEDs, so offer high reliability and low power consumption and heat generation.

Filters provide NVG compatibility with full compliance to MIL-STD-3009. Threaded bodies permit simple mounting, and connection is via flying leads. A range of NVIS lighting colours are available, identified by the colour of the positive wire.



Options available include:

- 5V, 12V or 28V DC or with no limiting resistor
- NVIS Red, NVIS Yellow, NVIS Green B, NVIS White, Blue

Advantages:

- Simple construction
- Robust sealed units
- High reliability
- Low power consumption
- Low heat generation
- Simple installation and connection
- NVG compatibility and chromaticity certified compliant to MIL-STD-3009 and DO-275

Consolite Technology Ltd, St. Martins Business Park, Bells Lane, Zeals, Wiltshire, BA12 6LY, UK

Tel: +44 (0)1747 840900
e-mail: sales@consolite.co.uk

Fax: +44 (0)1747 841500
Web: www.consolite.co.uk

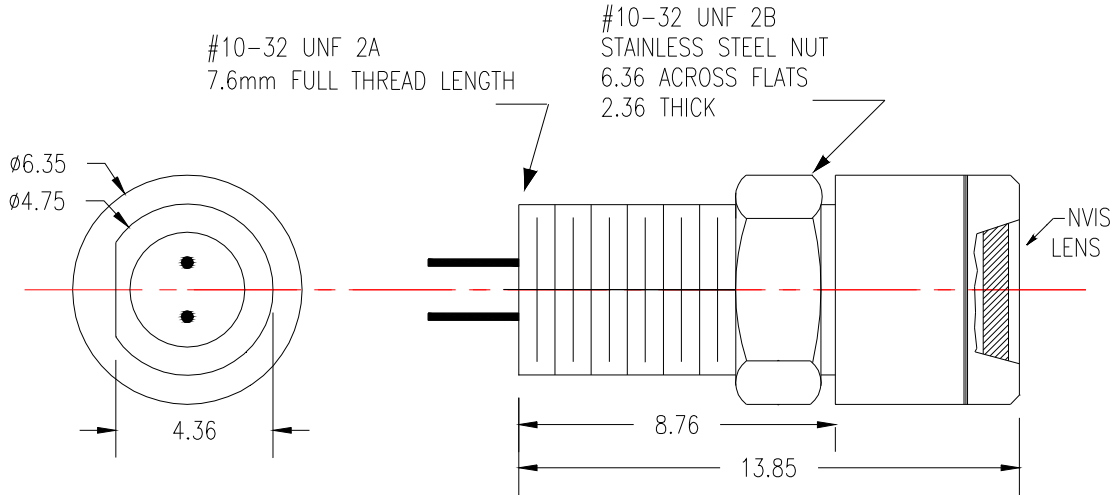

Part Numbers are of the form:

CTL-XXX-YYY

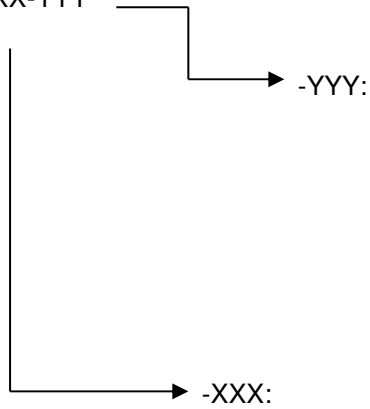

- YYY:
- 001 NVIS Green B
 - 002 NVIS Yellow
 - 003 NVIS Red
 - 004 Blue
 - 005 NVIS White

- XXX:
- 111 5V
 - 069 12V
 - 080 28V
 - 124 No limiting resistor

Example: CTL-080-002 denotes a 28V NVIS Yellow indicator

Consolite Technology Ltd, St. Martins Business Park, Bells Lane, Zeals, Wiltshire, BA12 6LY, UK

Tel: +44 (0)1747 840900
e-mail: sales@consolite.co.uk

Fax: +44 (0)1747 841500
Web: www.consolite.co.uk

Rev.3